

PLAN VIEW

**DOWN
SLOPE**

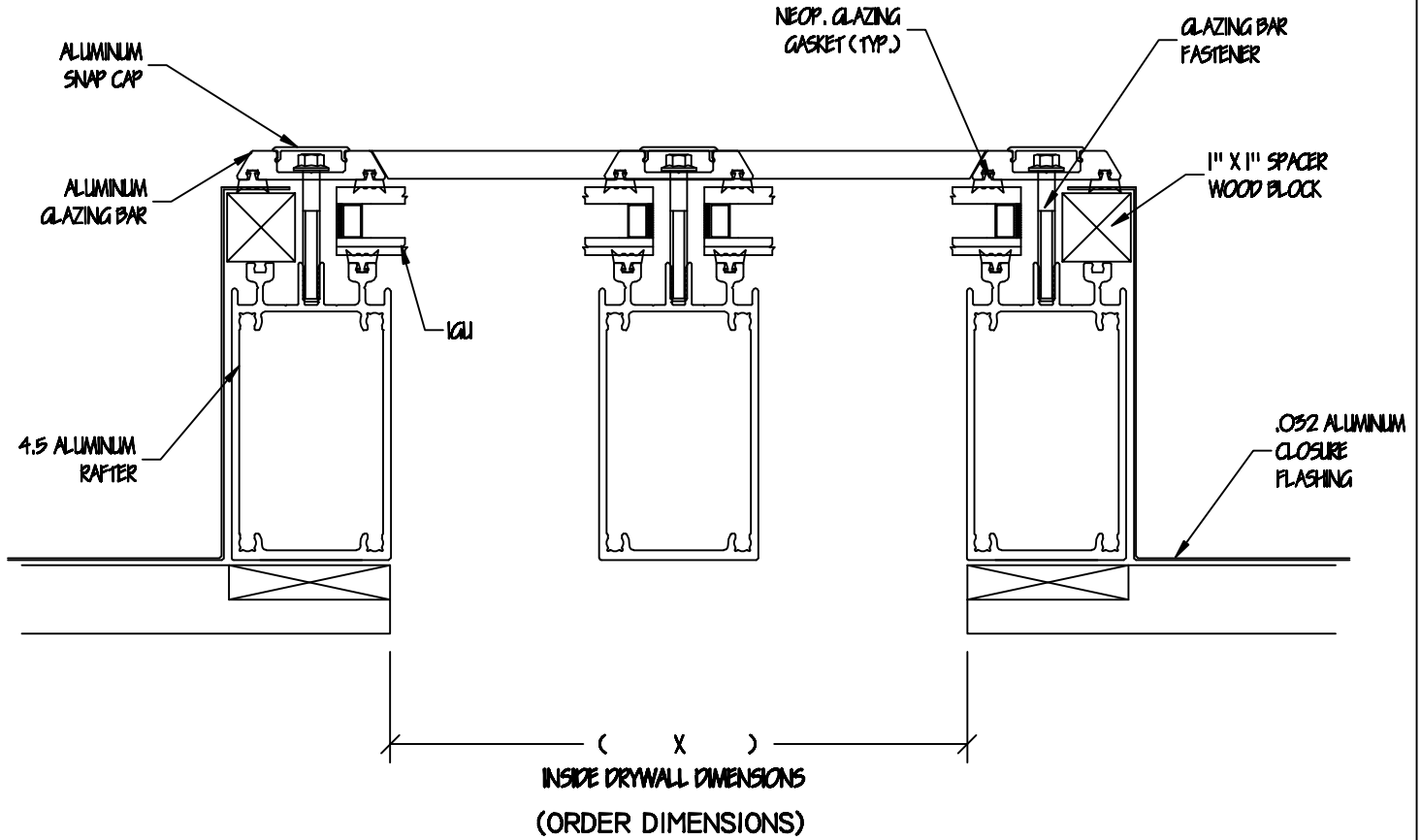
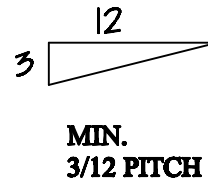

TWO BAY TANDEM SHOWN AS TYPICAL

NOTE:

- The flange-to-flange dimension is 1/2" larger than the outside dimension of curb, unless directed otherwise.
- Depending on size, unit may be shipped unglazed.
(call for details)

MODEL: X SFG-T

Tandem Self-Support; 2 Bays



TITLE: SELF SUPPORT GLASS TANDEM - DECK MOUNT

Date: August 05, 2013

Drawn By: AP Sheet: | of |

Rev. By: CRH

Engineer: CRH

ORCA Manufacturing, Inc.
P.O. Box 2186
Easton, MD 21601
Phone: 800-776-1539